

CN-2V 1500AH 铅酸蓄电池

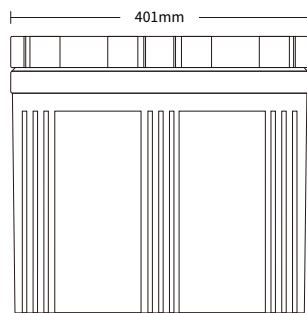
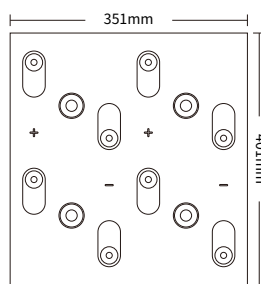
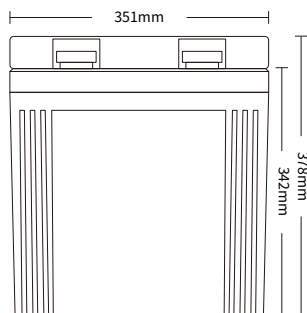

技术参数

额定电压	容量 (10hr, 1.80V/单体, 25°C)	重量	最大 放电电流	最大 充电电流	自放电 (25°C)	推荐使用温度	壳体材料
2V	1500Ah	92Kg	30I ₁₀ A(3min)	≤0.25C ₁₀	≤3%/月	15°C~25°C	ABS工程塑料
使用温度范围	充电电压 (25°C)	充电方式 (25°C)		循环寿命	温度对容量的影响		
放电: -45°C~50°C	浮充: 2.25V-2.3V	浮充使用: 2.275±0.025V		100%DOD 572 times	105% @ 40°C		
充电: -20°C~45°C	均充: 2.35V-2.4V	温度参数: ±3mV/°C		50%DOD 1422 times	90% @ 0°C		
储存: -30°C~40°C		循环使用: 2.45±0.05V		30%DOD 2218 times	70% @ -20°C		
		温度参数: ±5mV/°C					

特点

阀控密封胶体蓄电池, 是采用当代先进技术研制开发的新型高能蓄电池。在正常使用时无游离电解液, 无酸雾溢出, 维护使用方便, 可广泛用于太阳能、风能、电信通讯系统、不间断电源 (UPS) 等领域。该产品设计浮充使用寿命达6年以上。

不同终止电压、放电时间的放电电流 (安培, 25°C)

F.V/Time	5min	10min	15min	30min	45min	1h	2h	3h	4h	5h	8h	10h
1.60V	2576	2182	2060	1576	1194	960	579	423	341	287	198	163
1.65V	2273	2003	1939	1454	1143	915	564	414	334	282	195	160
1.70V	2182	1890	1848	1333	1071	864	543	402	327	278	192	158
1.75V	2079	1793	1751	1242	1023	831	525	390	318	270	189	154
1.80V	2000	1701	1651	1182	951	777	501	378	306	264	184	150
1.85V	1770	1507	1463	1070	861	702	453	357	293	252	178	146

认证

ISO9001
CE
符合的标准:
GB/T 22473-2008
GB/T 19638.2-2005
YD/T799-2002
IEC61427-2005
GB/T 19001-2016 idt ISO 9001:2015
EN IEC 61000-6-2:2019, EN IEC 61000-6-4:2019
EN IEC 61000-3-2:2019+Al:2021
EN 61000-3-3:2013+Al:2019



充电特性

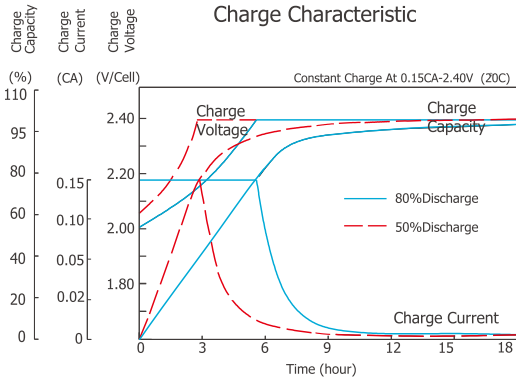

放电特性 (25°C)

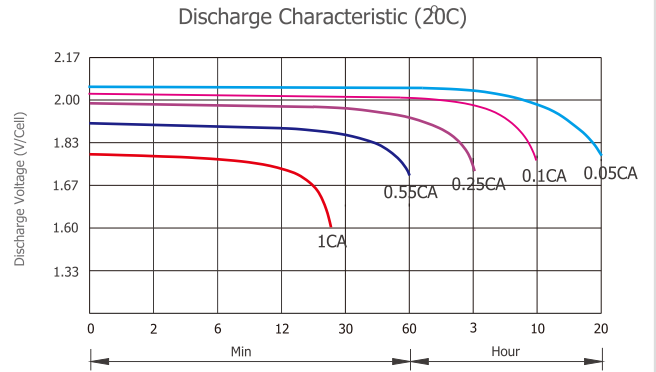

温度与寿命

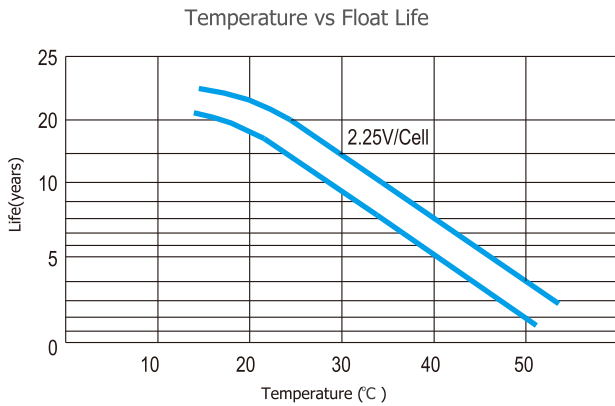

放电特性

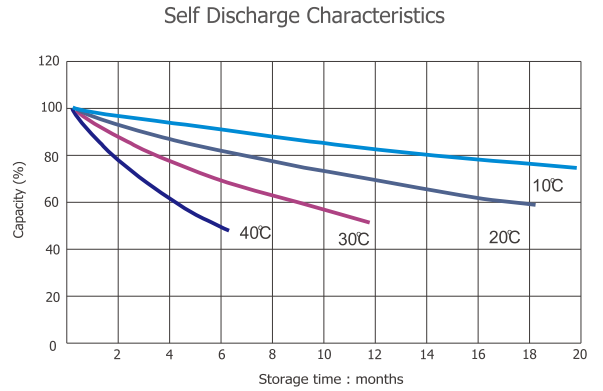

放电深度与循环次数

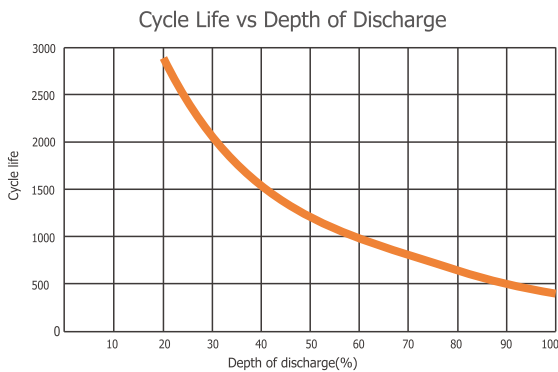

温度与容量

